

Drawings of the cooker

- 1. Base
- 2. Heart of the fire
- 3. Holding place for pots
- 4. Grill

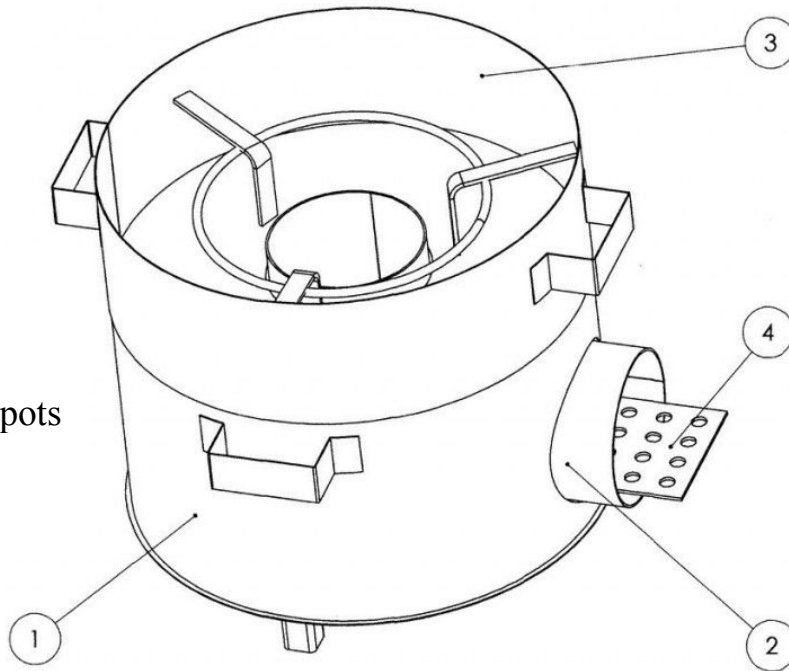

LYCEE F.BUISSON - 76500 ELBEUF
CUISEUR TYPE BURKINABE

All 4 parts are independent, not welded together

1. Base

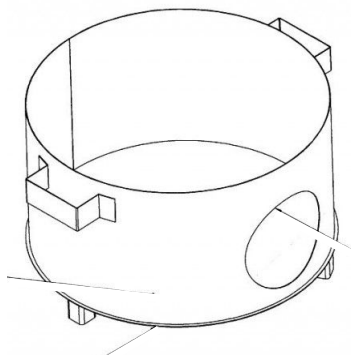

2. Holding place for pots

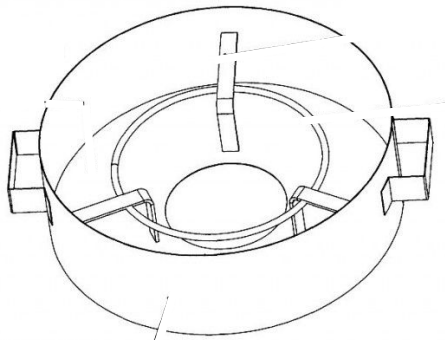

2/4. Heat of the fire/Grill

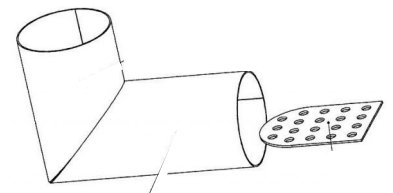

1. Base

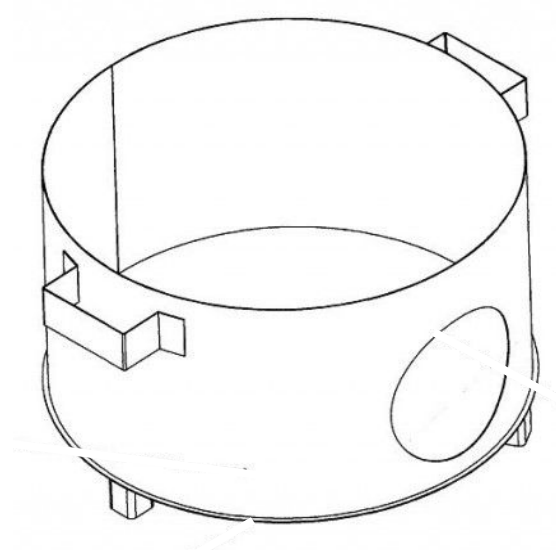
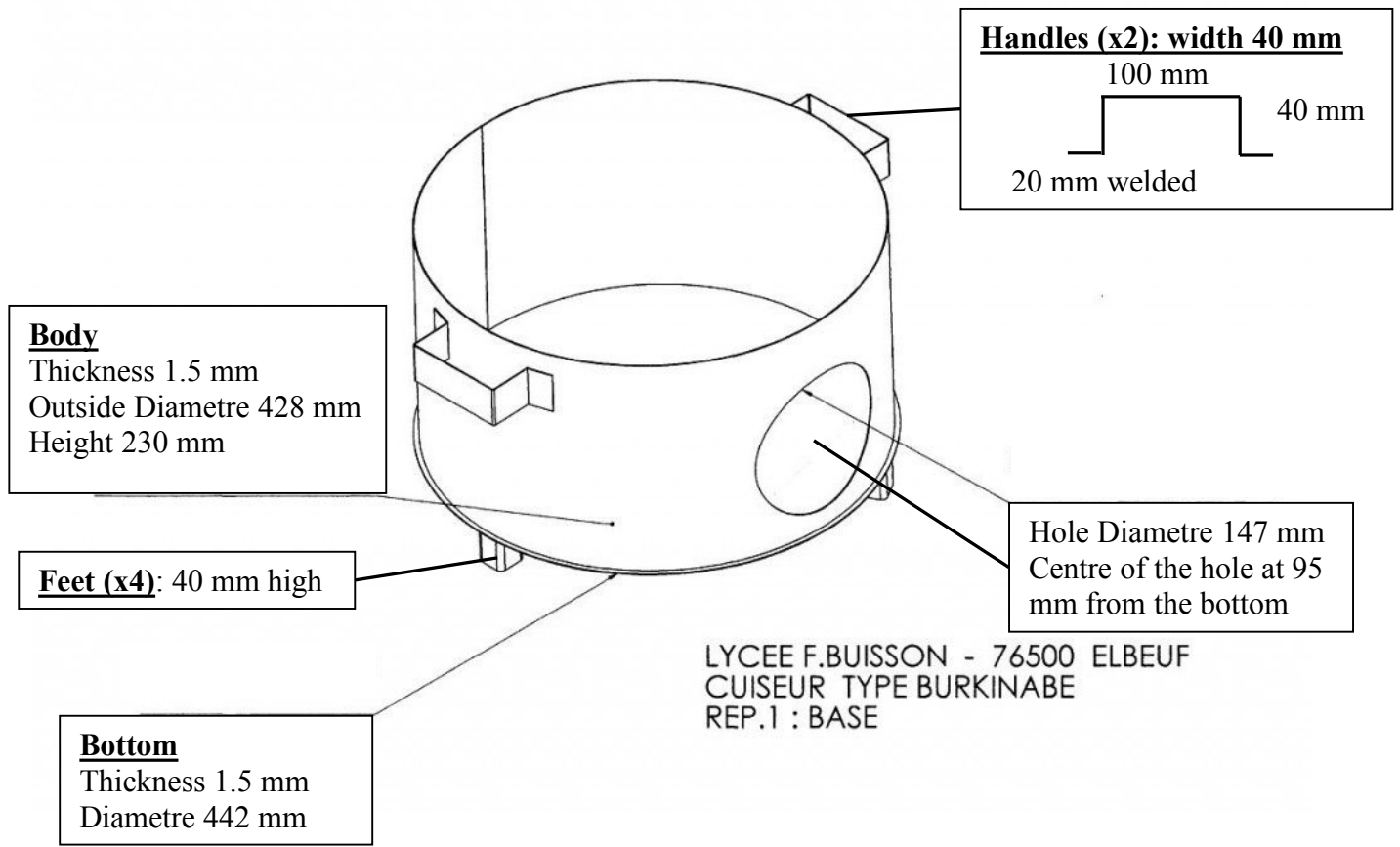

Material

Metal sheet 1.5 mm: 0.5 m²
Off cut for handles

Feet

3. Holding place for pots

Bottom

Thickness 1.5 mm
Outside Diametre 432 mm
Diametre Hole in centre
147 mm
Welded at 7 mm from
bottom of body

Plates (x3) 20x4 mm

Length x height = 120x75 mm
with a bend at 95°

Ring

Plain pipe 8 mm thick
Inside Diametre 250 mm

Body

Thickness 1.5 mm
Outside Diametre 435 mm
Height 136 mm

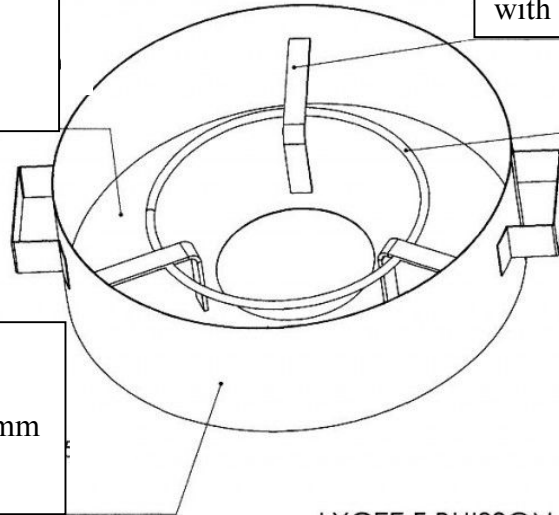

LYCEE F.BUISSON - 76500 ELBEUF
CUISEUR TYPE BURKINABE
REP.3 : SUPPORT PLAT

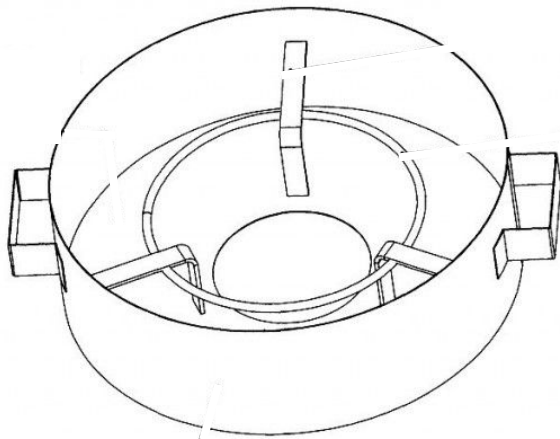

Material

Metal sheet 1.5 mm: 0.4 m²

Plain pipe 8 mm thick: 785 mm

Flat 20x4 mm: total length 585 mm

2/4. Heart of the fire / Grill

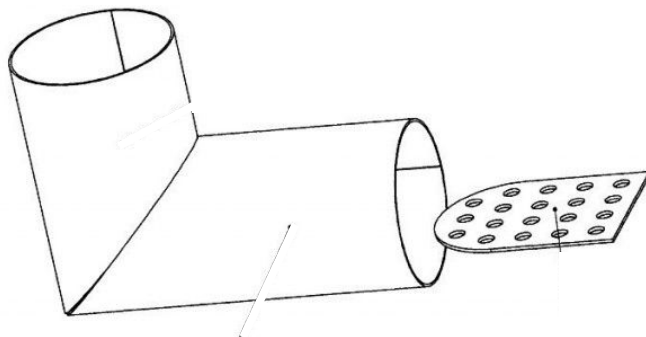
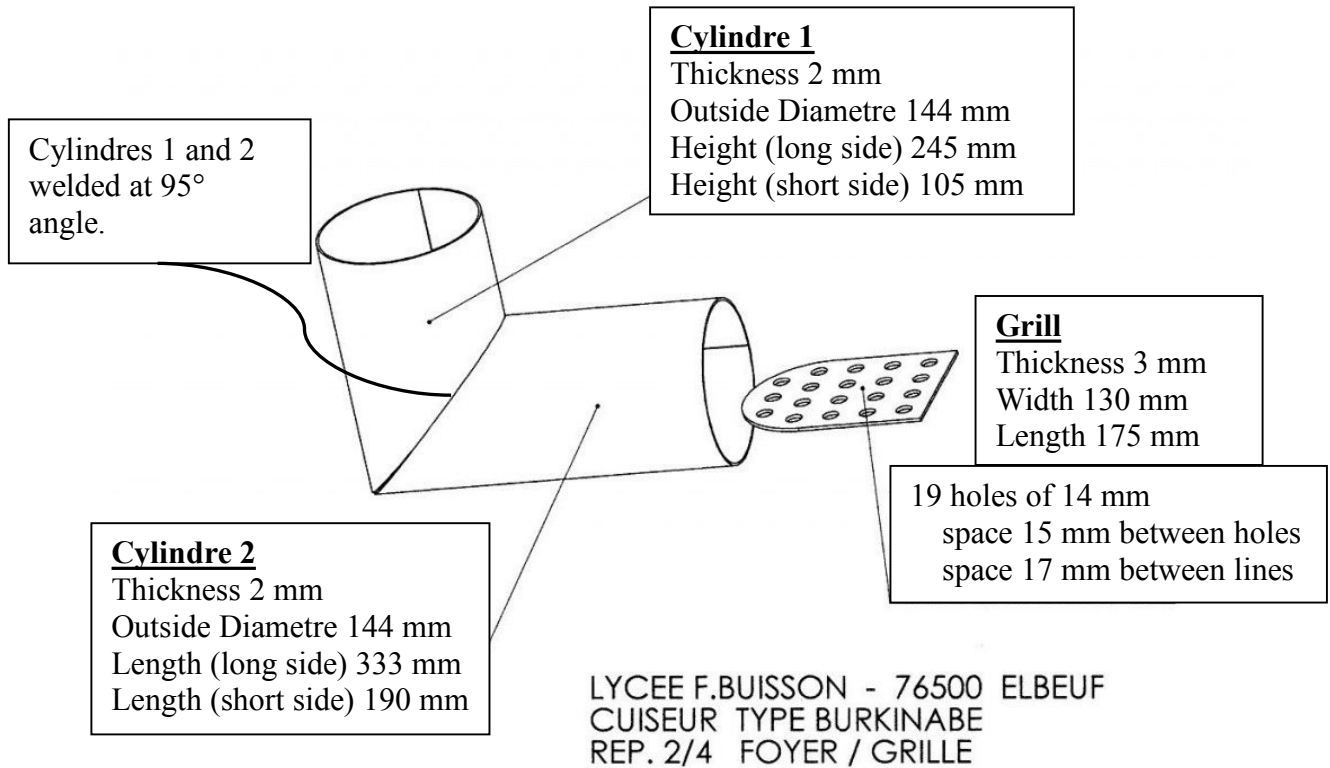

Material

Metal sheet 2 mm: 0.3 m²

Metal sheet 3 mm: size 130x175 mm: 0.2 m²